

WRACE BOATS

DONOVAN 26 OD

CHARLESTON
RACE WEEK
SPERRY

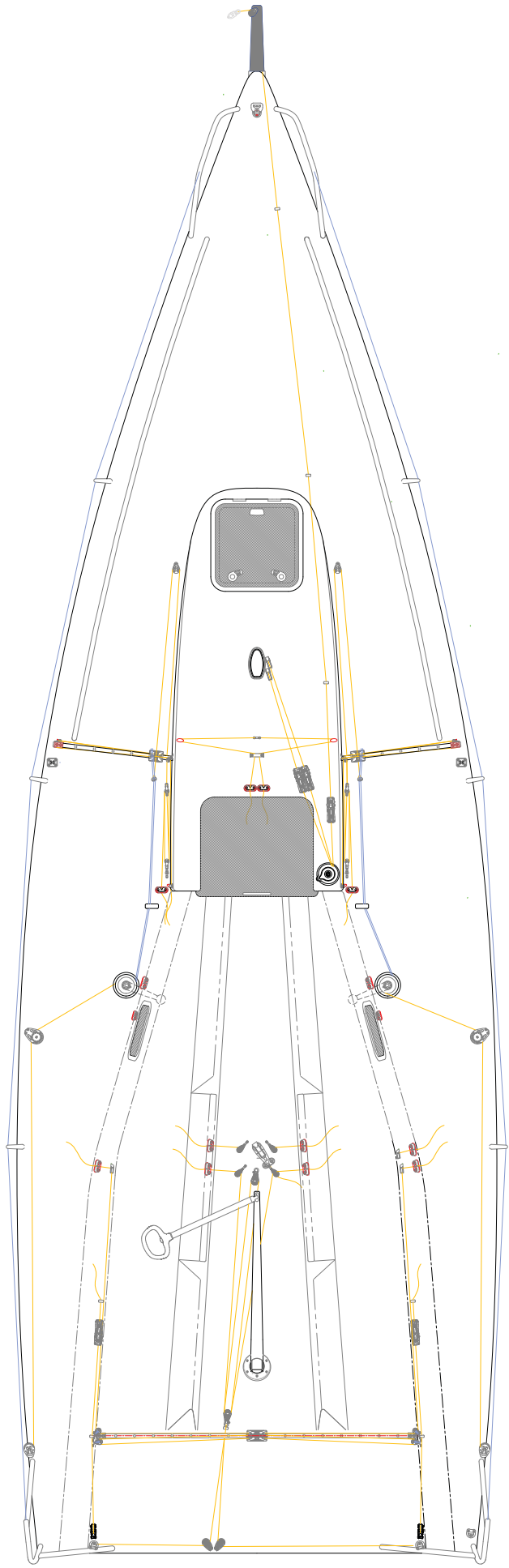



DONOVAN 26 ONE DESIGN © jp donovan DESIGN LLC - 12 December 2017 - all rights reserved

DESIGNER'S COMMENTS

The Donovan 26 One Design is an evolution of the successful GP26 built by Wraceboats. This design demonstrated exceptional speed and control at regattas in the U.S., Europe and Asia, regularly finishing ahead of the competition and gaining praise from the crews who sailed aboard. The Donovan 26 One Design retains all the attributes of its predecessor featuring a stable and balanced hull form, deep fin keel with 47% ballast ratio, efficient carbon fiber rudder, and easily controlled and tough carbon fiber rig. The sailplan has been upgraded with a larger square-top mainsail and extended sprit to provide extra power for higher performance. Stepping aboard the boat the impression is this is a much larger yacht; the spacious cockpit has been extended forward, deck house reduced and hardware refinements include a standard spinnaker takedown system. Advanced construction utilizes epoxy vacuum laminates with an all carbon fiber keel frame and carbon appendages that produce an extremely durable light weight structure. You owe it to yourself to go for a sail aboard a Donovan 26 One Design to experience this superior racing yacht.

Jim Donovan / jp donovan DESIGN

Main Characteristics

Length overall	7.90 m	25.9 ft
Max. beam.	2.55 m	8.4 ft
Draft	1.9 m	6.2 ft
Empty Displacement	1050 +/- 25kg	2315 lb +/- 55
Keel Bulb	445 kg	981 lb
Keel Total	480 kg	1058 lb

Rig

IG	9.25 m	30.3 ft
ISP	11.15 m	36.6 ft
P	9.97 m	32.7 ft
E	3.85 m	12.6 ft
J	2.90 m	9.5 ft
TPS	5.60 m	18.4 ft
LP	3.10 m	10.2 ft

Sail Areas

Main	31.0 m ²	334 ft ²
Jib	15.3 m ²	165 ft ²
Asymmetric Spinnaker	85.0 m ²	915 ft ²

SPECIFICATION

The Specification for the Boat is as set out below or as identified below and attached to this Agreement and signed by the Parties.

Standard Boat: Standard Boat: Donovan 26 OD Racing Yacht designed by JP Donovan Design LLC

- Hull, deck, bulkheads and internal structures constructed with vacuum molded E- glass, epoxy resin and closed cell foam cores. Construction system utilizes separate vacuum procedures for outer hull and deck laminates, core bonding, inner hull and deck laminates and reinforcements to insure the highest quality laminates, core bonds and resin content control.
- Meets with EC Directive 94/25/EC, EC Design Category C, Module A, and Offshore Special Regulations Category 4 (when Buyer's safety equipment is added).
- Carbon reinforced keel support structure integrated composite shroud chainplates
- Carbon composite rudder blade and stock with Jefa upper & lower bearings, carbon tiller.
- Carbon composite keel fin, fixed configuration with simple removal for transport/service.
- Solid cast lead bulb pinned and bonded to keel fin.
- Standard hull topsides gelcoat finish
- Boat bottom, below the chine Race Finish: 1-Barrier Coat, 2-High Build Epoxy 3- Epoxy Primer Paint sanded to 600 grit. NO GELCOAT below chine
- Standard deck gelcoated shiny surfaces and semi-gloss white Polyurethane non-skid.
- Interior middle painted in semi-gloss PU finish
- Open racing interior with two molded berths under cockpit sides.
- Harken & Spinlock deck hardware per JP Donovan Design LLC Deck Layout
- Lewmar foredeck hatch, 2 x Lewmar Portlights
- Stainless steel stanchions; bow pulpit and stern pushpits. Upper and lower stainless steel lifelines
- Carbon mast, carbon boom and carbon bowsprit built by Pauger Carbon Composites. Stainless steel rod shrouds and forestay. Composite topmast runners by BSI, with deflector system, Windex, masthead tri-color navigation light
- Running Rigging
- Manual bilge pump BP9013 Gusher Urchin
- 12v control panel, 12v/24Ah battery with battery box.
- Composite Cradle Saddles, Cradle Connection Pieces
- Stainless Steel Outboard Bracket



DONOVAN26
ONE DESIGN

BUYER:
ADDRESS:

Work Phone
Fax Number
Mobile Phone
Home Phone

E-mail:

BUILDER Mag Marin Yatçılık Turizm San. Tic A.S. Deri Organize San. Bölgesi Kazlıçesme Cad. No31 F9 Özel Parsel Tuzla İstanbul Turkey
T:216 3941613 F:216 3941638 @info@magmarin-tr.com WWW.Wraceboats.com

BASE BOAT	PRICE	TOTAL
Hull # as per Standard Specifications in Exhibit A Page 2 of 2		\$82,224.00
OPTIONS		
Hull Topsides Hi Gloss Interlux Perfection Paint other than white	\$520	
Clear Coated Carbon Tiller in Lieu of Gelcoat	\$380	
Clear Coated Carbon Keel Support Structure in Lieu of Gelcoat	\$980	
Companionway Entry Ladder, Aluminum with one step	\$420	
Triad Tandem Lift-off trailer with 4 wheel electric brakes (Delivered to Annapolis MD)	\$6,090	
INSTRUMENT OPTIONS		
Tactick T108 (Racing Instruments with 2 screens: wireless wind transducer, speed, depth and temperature Triducer)	\$2,230	
Tactick T908 GPS Antenna	\$510	
Tactick T909 Compass Transducer	\$275	
Custom Electronics Packages Available. Contact Stagg Yachts for Details and Pricing		
MISCELLANEOUS:		
Shipping Cradle & Packaging		Included
CIF ANNAPOLIS, MARYLAND, USA (Excludes Duty and Customs Handling Charges and Fees to be paid by Buyer)		Included
BASE BOAT PRICE:		\$82,224
OPTIONAL EXTRAS:		
TOTAL PRICE (terms here)		\$82,224
TOTAL CONTRACT PRICE:		\$82,224
PRODUCTION START DATE		
ESTIMATED FINISH DATE		
TERMS		
10% at signing		8,222
40% prior to commencement of hull construction		32,890
40% at joining of hull and deck		32,890
10% upon completion and at least 2 weeks before shipment		8,222
Signed _____	DATE: _____	
BUYER:		
Signed _____	DATE: _____	
DEALER:		
Signed _____	DATE: _____	
BUILDER: Mag Marin Yatçılık Turizm San. Tic A.S. Deri Organize San. Bölgesi Kazlıçesme Cad. No31 F9 Özel Parsel Tuzla İstanbul Turkey		

BOAT REMAINS PROPERTY OF MAG MARIN YATÇILIK UNTIL PAID IN FULL.

MAG MARIN YATÇILIK RESERVES THE RIGHT TO CHANGE BASE BOAT PRICES/SPECIFICATIONS WITHOUT NOTICE UP UNTIL RECEIPT OF A SIGNED ORDER FORM AND PAID DEPOSIT

EC – TYPE EXAMINATION CERTIFICATE

MANUFACTURER

Mag Marin Yatçılık Turizm Sanayi Ticaret A.Ş
İstanbul Deri Organize Sanayi Bölgesi
1ci Yol F9 A Parsel Tuzla
İstanbul/ Turkey 34956

TYPE OF BOAT and CONSTRUCTION

SAILBOAT – FIBER REINFORCED PLASTIC-COMPOSITE

MODEL NAME

WRACEBOATS GP26

SPECIFICATIONS

LENGTH OVERALL	7,90 m (ISO 8666)
MOULDED BEAM	2,55 m (ISO 8666)
DEPTH	1,90 m (ISO 8666)

DESIGN CATEGORY

C

DESIGN MODULE

A

We hereby declare the boat stated above meets with the EC Directive 94/25/EC

DATE & STAMP

June 16 2016